



Weather Shield® 6204/8204 Parts Reference Catalog

#1202614

Premium Windows & Doors

FOR PRODUCT PRODUCED AFTER 02/06

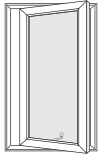

Casement

CASEMENT

Awning



AWNING

French Casement

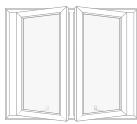

FRENCH
CASEMENT

Scena-Vu

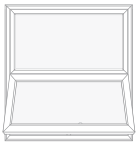

SCENA-VU

Bow/Bay

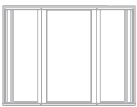

BOW/BAY

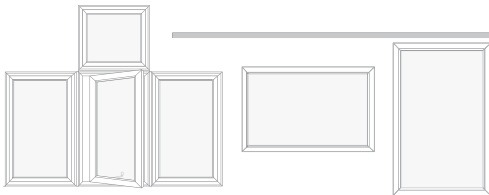

- Mull/Stack
- Transom
- Picture

MULL/STACK
TRANSOM
PICTURE

Order Form



ORDER
FORM

Measuring

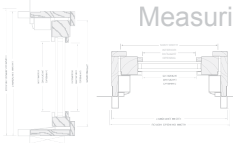

MEASURING

Weather Shield Mfg., Inc.
Medford, WI 54451 • 715-748-2100



TABLE OF CONTENTS:

Primed Casement Exploded View	1
Aluminum Clad Casement Exploded View	2
Casement Replacement Parts	3
Screen/Energy Panel Exploded View	9
Screen/Energy Panel Replacement Parts	10

DESCRIPTION:

Wood window with aluminum or wood exterior.

INTERIOR OPTIONS:

Species: Pine, Knotty Pine, American Fir, Oak, Cherry, Maple, Mahogany, Alder

Finish: Natural, Primed, Poly (Standard, Designer, or Custom Color)

EXTERIOR OPTIONS:

Wood: Natural, Primed, Poly (Standard, Designer, or Custom Color)

Clad: White, Cameo, Desert Tan, Western Adobe, Craftsman Bronze, Obsidian, Hartford Green, Designer Color, Custom Color, Anodized finish.

HARDWARE OPTIONS:

Bright Brass, Goldtone, White, Adobe, Oil Rubbed Bronze, Brushed Nickel, Brushed Chrome

DISTINGUISHING FEATURES:

- Aluminum and/or wood construction
- 4-9/16" jamb depth
- Wood interior

HOW TO ORDER A PART:

Identify the part using the **exploded view** and index. Locate the part in the **replacement parts** section using the **reference number** from the exploded view and index for a detailed part view and ordering information. Use the **configured number**, **extrusion number**, and/or **part number** shown next to your part to place your order. **When identifying replacement parts, unit must be viewed from the exterior.**

- Exploded View:** Drawings show part location and are accompanied by indexes that reference part descriptions.
- Replacement Parts:** Sections contain detailed views of individual replacement parts and ordering information.
- Reference Number:** Shown in black boxes on the exploded views and listed numerically in the indexes. Parts appear sequentially by reference number in the replacement parts sections.
- Configured Number:** Use to enter your order in CustomQuote™.*
- Extrusion Number:** Reference when placing an order with your Customer Relations Representative.
- Part Number:** Reference when placing an order with your Customer Relations Representative.

* **NOTE:** Some configured numbers MAY NOT be active at the time of your order. CustomQuote™ software is updated regularly to accommodate new configured numbers. If a configured number is not active, please comment the part for ordering. Contact your Customer Relations Representative for assistance.

GLASS IDENTIFICATION CODE:

The glass code number references the date of manufacture, which is helpful in identifying the product.

When ordering warranty replacement glass, sash or panels, it is necessary to specify the glass identification code.

Markings are stamped on one of the four sides of the spacer which separates the two panes of glass. (see illustration at right)

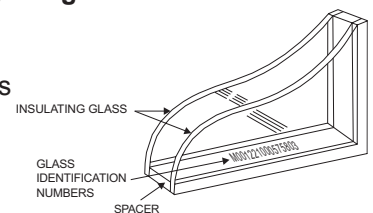



CASEMENT

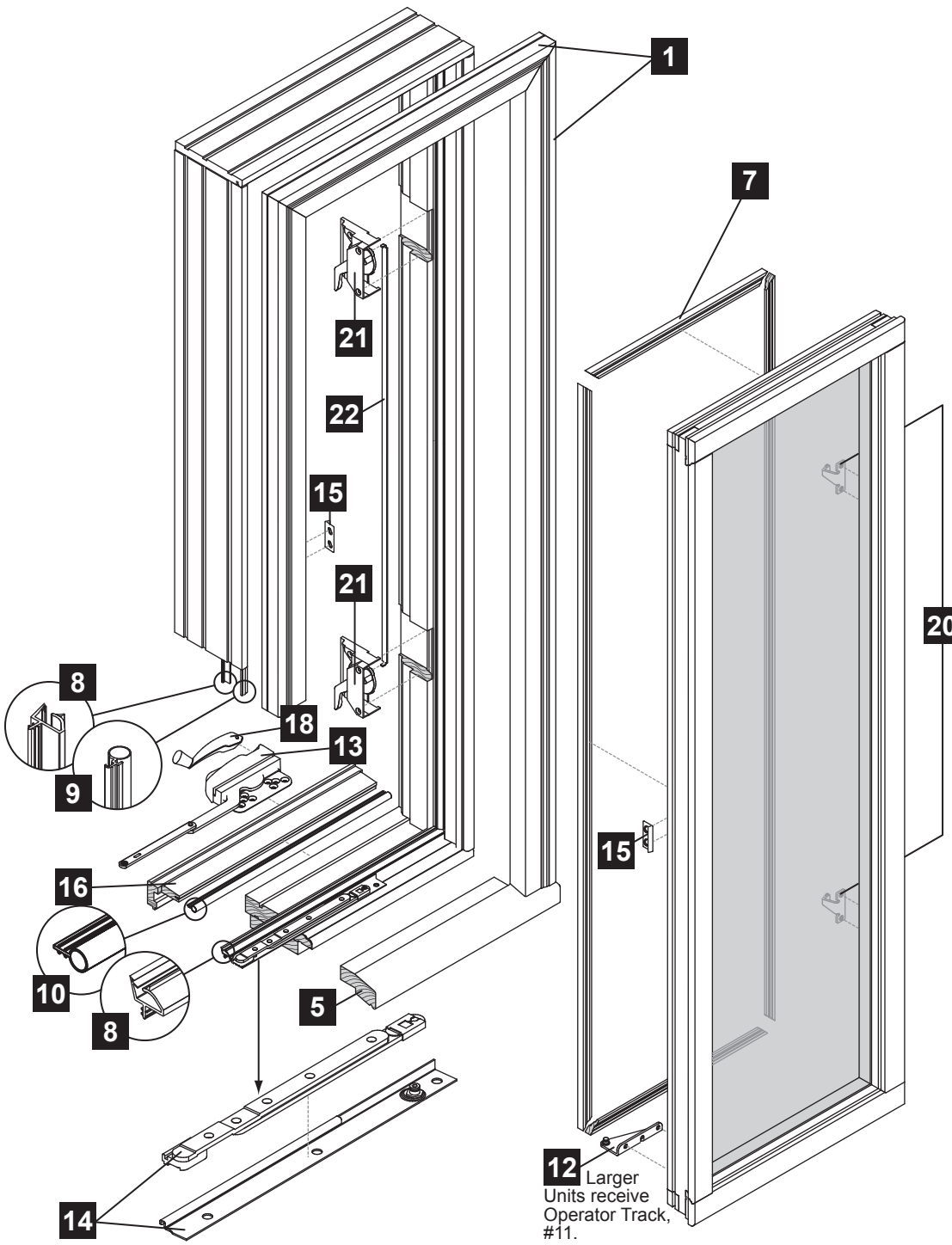

Parts Shown	Page
1 Exterior Trim	3
5 Subsill	3
7 Glazing Bead	4
8 Dual Seal Weatherstrip	4
9 Bulb Weatherstrip ¹	4
10 Bulb Weatherstrip ²	4
12 Sash Bracket	5
13 Operator	5-6
14 Hinge	6
15 Snubber	6
16 Operator Cover	6
18 Operator Handle	7
20 Keeper	8
21 Sash Lock	8
22 Tandem Lock Tie Bar	8

¹ For Head/Side
² For Operator Cover

Parts Not Shown	Page
11 Operator Track	4
17 Limit Stop	6
19 Handle Extension	7
23 Jamb Extension	8



CASEMENT

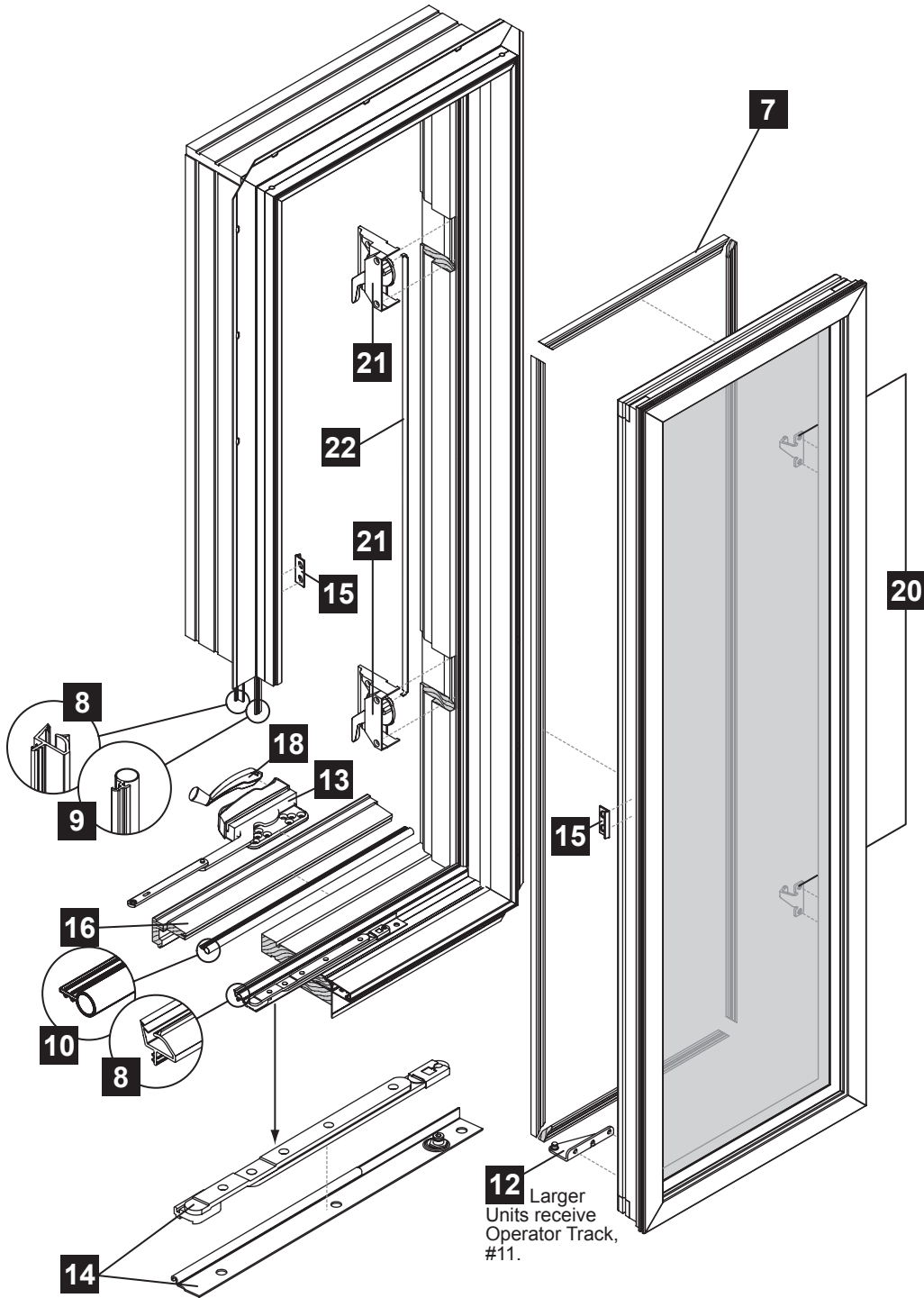

Parts Shown	Page
7 Glazing Bead.....	4
8 Dual Seal Weatherstrip.....	4
9 Bulb Weatherstrip ¹	4
10 Bulb Weatherstrip ²	4
12 Sash Bracket.....	5
13 Operator.....	5-6
14 Hinge.....	6
15 Snubber.....	6
16 Operator Cover.....	6
18 Operator Handle.....	7
20 Keeper.....	8
21 Sash Lock.....	8
22 Tandem Lock Tie Bar.....	8

¹ For Head/Side
² For Operator Cover

Parts Not Shown	Page
2 Exterior Trim.....	3
3 1" Brickmould Corner Key.....	3
4 Brickmould Corner Key.....	3
6 Subsill.....	3
11 Operator Track.....	4
17 Limit Stop.....	6
19 Handle Extension.....	7
22 Drip Cap.....	8
23 Jamb Extension.....	8



1 Wood Exterior Trim

Specify Finish _____
(See pg. i, Exterior Options, for information)

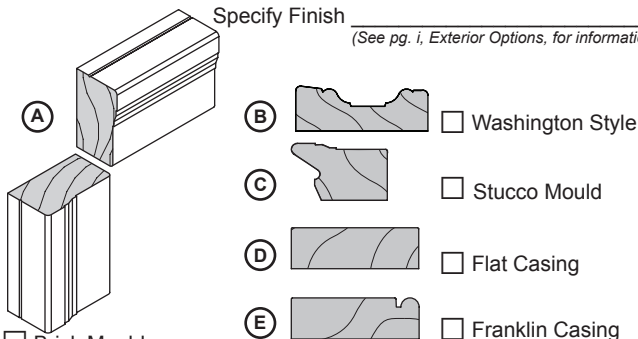

Brick Mould

Washington Style

Stucco Mould

Flat Casing

Franklin Casing

NOTE: For replacement on radius units, refer to Order Form section.

- A) Configured Number: C1159706
- B) Configured Number: C1159703
- C) Configured Number: C1159696
- D) Configured Number: C1159718
- E) Configured Number: C741768

2 Aluminum Exterior Trim

Specify Color _____
(See pg. i, Exterior Options, for information)

Items 3,4, and/or 6 may need to be ordered with your trim.

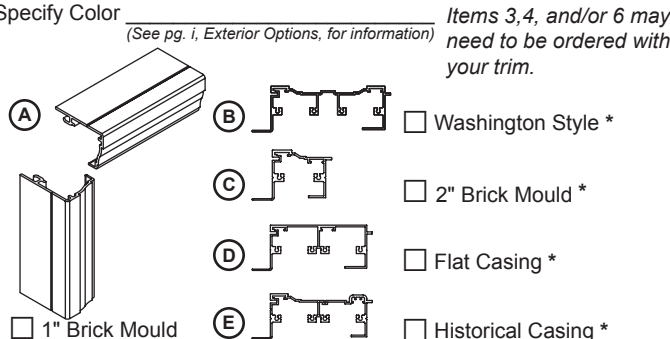

1" Brick Mould

Washington Style *

2" Brick Mould *

Flat Casing *

Historical Casing *

NOTE: For replacement on radius units, refer to Order Form section. * For pre-installation replacement only.

- A) Configured Number: C963443 Extrusion Number: 04-2183
- B) Configured Number: C968635 Extrusion Number: 1528
- C) Configured Number: C968621 Extrusion Number: 1549
- D) Configured Number: C968628 Extrusion Number: 1545
- E) Configured Number: C963664 Extrusion Number: 04-2181

3 1" Aluminum Brickmould Corner Key



Pack contains:
 (2) Insect Barrier
 (2) Corner Key
 (2) #7 x 3/4" 410 SS panhead screws
 (4) #8 x 3/8" flat head screws
 (1) Instruction sheet

Part Number: 1162737

4 Aluminum Brickmould Corner Key

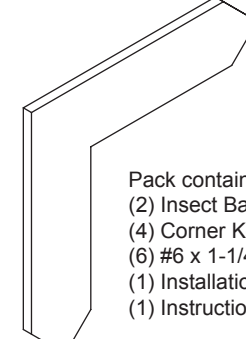

Pack contains:
 (2) Insect Barrier
 (4) Corner Key
 (6) #6 x 1-1/4" 410 SS w/ #5 flat head screws
 (1) Installation Instructions
 (1) Instruction sheet

Part Number: 1162738

5 Wood Subsill

Specify Finish _____
(See pg. i, Exterior Options, for information)

For pre-installation replacement only.

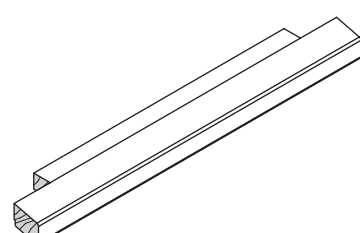

Configured Number: C310010

6 Aluminum Subsill

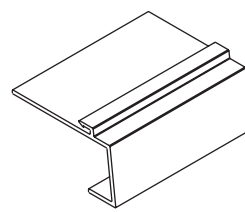

Configured Number: C968571
Extrusion Number: 1552



CASEMENT

7 Glazing Bead

Specify Species/Finish

(See pg. i, Interior Options, for information)

Putty:

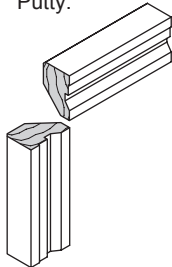

Insul/Triple Insul



1/8"-1/4" Single Glaze



7/16"-9/16" Single Glaze

Colonial:

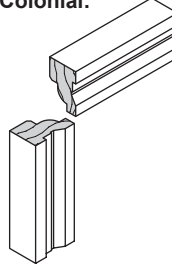

Insul/Triple Insul

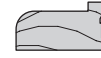

1/8"-1/4" Single Glaze



7/16"-9/16" Single Glaze

Configured Number: (Putty) C311502
(Colonial) C110239

8 Dual Seal Weatherstrip

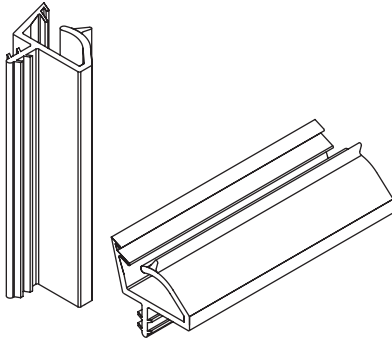

Configured Number: C750769
Extrusion Number: 60-4714

9 Bulb Weatherstrip (Head & Side Jamb)

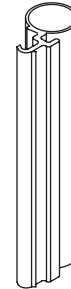

Configured Number: C740392
Extrusion Number: 2010

10 Bulb Weatherstrip (Operator Cover)

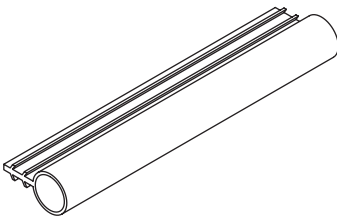

Configured Number: C761553
Extrusion Number: 5090

11 Operator Track

Finish	Part Number	
	11-3/8"	13-3/4"
Standard	972045	940006
Stainless Steel	972920	940013

- 11-3/8"
- 13-3/4"



Contact your Customer Relations Representative for ordering.

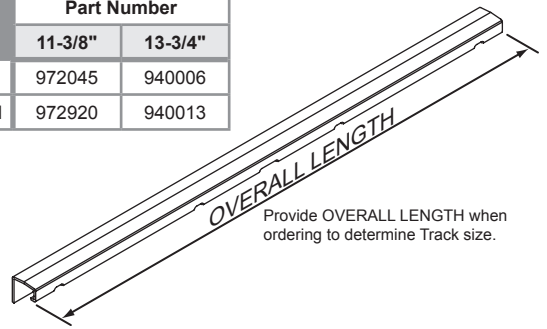

Provide OVERALL LENGTH when ordering to determine Track size.

Part Number: (Standard) 972045
(Stainless Steel) 972920



CASEMENT

12 Sash Bracket

Finish	Part Number	
	Left	Right
Standard	972010	972039
Seacoast	972782	972781

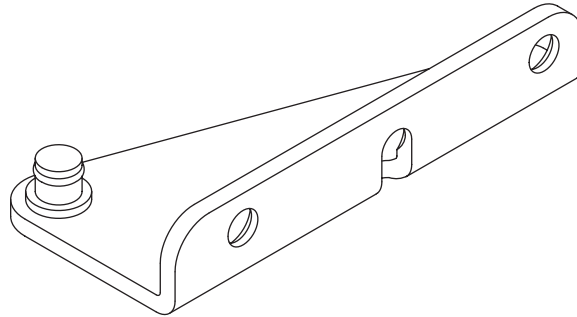

Contact your Customer Relations Representative for ordering.

Lefthand Shown
Righthand Opposite

13a Single Arm Operator

Finish	Part Number							
	Left				Right			
	9-1/2"		13-1/2"		9-1/2"		13-1/2"	
	Standard	Seacoast	Standard	Seacoast	Standard	Seacoast	Standard	Seacoast
White	942125	942212	942139	942226	942132	942219	942146	942233
Goldtone	942126	942213	942140	942227	942133	942220	942147	942234
Adobe	942127	942214	942141	942228	942134	942221	942148	942235
Bright Brass	942128	N/A	942142	N/A	942135	N/A	942149	N/A
Oil Rubbed Bronze	942129	N/A	942143	N/A	942136	N/A	942150	N/A
Brushed Nickel	942130	N/A	942144	N/A	942137	N/A	942151	N/A
Brushed Chrome	942131	N/A	942145	N/A	942138	N/A	942152	N/A

- 9-1/2"
- 13-1/2"

Provide ARM LENGTH when ordering to determine Operator size.

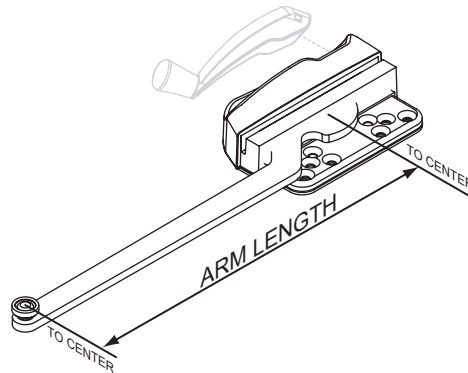

Righthand Shown
Lefthand Opposite



13b Split Arm Operator

Finish	Part Number			
	Left		Right	
	Standard	Seacoast	Standard	Seacoast
White	942111	942198	942118	942205
Goldtone	942112	942199	942119	942206
Adobe	942113	942200	942120	942207
Bright Brass	942114	N/A	942121	N/A
Oil Rubbed Bronze	942115	N/A	942122	N/A
Brushed Nickel	942116	N/A	942123	N/A
Brushed Chrome	942117	N/A	942124	N/A

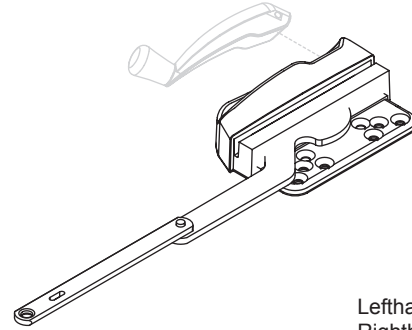

Lefthand Shown
Righthand Opposite

14 Hinge

Finish	Part Number			
	Left		Right	
	10"	14"	10"	14"
Standard	972922	941074	972923	941075
Stainless Steel	972660	941047	972661	941048

For rectangular Casements with Nominal Glass Heights below 68".

Provide OVERALL LENGTH when ordering to determine Hinge size.

10"
 14"

FASTENERS NOT INCLUDED
Contact your Customer Relations Representative for ordering.

Righthand Shown
Lefthand Opposite

15 Snubber

Snubber usage and quantity varies depending on unit size

FASTENERS NOT INCLUDED
Contact your Customer Relations Representative for ordering.

Part Number: 972524

16 Operator Cover

Specify Species/Finish _____
(See pg. i, Interior Options, for information)

Specify Unit Size* _____
** width and height (See Measuring Section for information)*

Split Arm Operator
 Single Arm Operator

Left
 Right

Configured Number: C310018

17 Limit Stop

Standard
 Stainless Steel

Part Number: (Standard) 972167
(Stainless Steel) 972252



CASEMENT

18a Folding Handle

Finish	Part Number
White	942167
Goldtone	942168
Adobe	942169
Bright Brass	942170
Oil Rubbed Bronze	942171
Brushed Nickel	942172
Brushed Chrome	942173

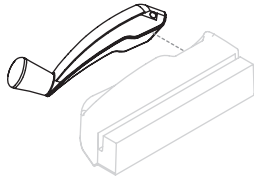

18b Contour Handle

Finish	Part Number
White	941911
Goldtone	941907
Adobe	941915
Bright Brass	941917
Oil Rubbed Bronze	941922
Brushed Nickel	941918
Brushed Chrome	941923

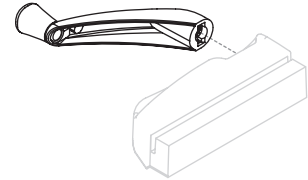

18c T Handle

Finish	Part Number
White	972991
Goldtone	972268
Adobe	972648
Bright Brass	972393
Oil Rubbed Bronze	941435
Brushed Nickel	941436
Brushed Chrome	941437

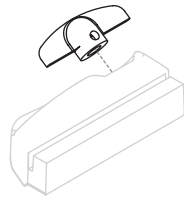

18d Round Handle

Finish	Part Number
White	940044
Goldtone	972069
Adobe	972130
Bright Brass	972338
Oil Rubbed Bronze	941438
Brushed Nickel	941439
Brushed Chrome	941440

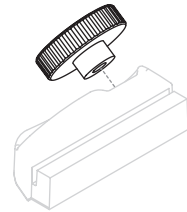

18e ADA Handle

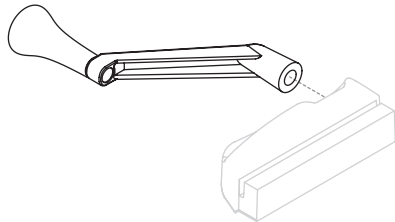

Please comment ADA Handle when ordering. Contact your Customer Relations Representative for assistance.

19 Handle Extension

- 2"
- 4"

Available in Goldtone only.

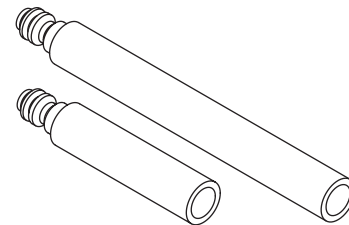

Part Number: (2") 972067
(4") 972068



CASEMENT

20a E-Guard Keeper

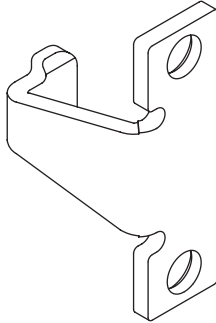

Contact your Customer Relations Representative for ordering.

Part Number: 972009

20b Reinforced Keeper (DP50 Upgrade)

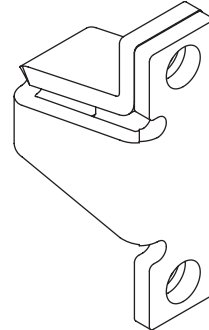

Available in
Stainless Steel
only.



Contact your Customer Relations Representative for ordering.

Part Number: (Left) 982502
(Right) 982503

Lefthand Shown
Righthand Opposite

21 Sash Lock

Finish	Part Number	
	Left	Right
Oil Rubbed Bronze	941423	941426
Brushed Nickel	941424	941427
Brushed Chrome	941425	941428
Goldtone	972003	972000
Bronze	972125	972126
Bright Brass	972164	972165

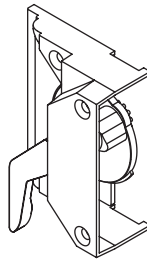

Lefthand Shown
Righthand Opposite

22 Tandem Lock Tie Bar

Overall Length	Part Number
25"	942291
29"	942292
33"	942293
43"	942294

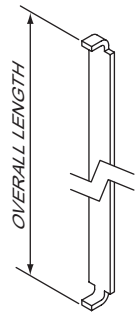

22 Drip Cap

Specify Color _____
(See pg. i, Exterior Options, for information)

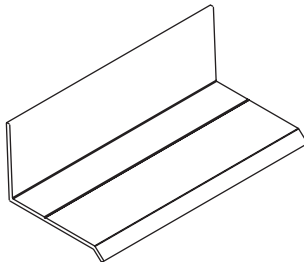

Configured Number: C963395
Extrusion Number: 04-2064

23 Jamb Extension

Specify Species/Finish _____
(See pg. i, Interior Options, for information)

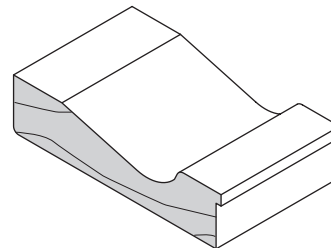

Configured Number: (each) C1027663
(set) C010000-JES



Parts Shown	Page
1 Screen Tab	10
2 Screen Spline	10
3 Screen Spring	10
4 Energy Panel Clip	10
5 Angled Pile Weatherstrip	10

CASEMENT

NOTE: CLAD UNIT SHOWN.
PRIMED UNIT SIMILAR.

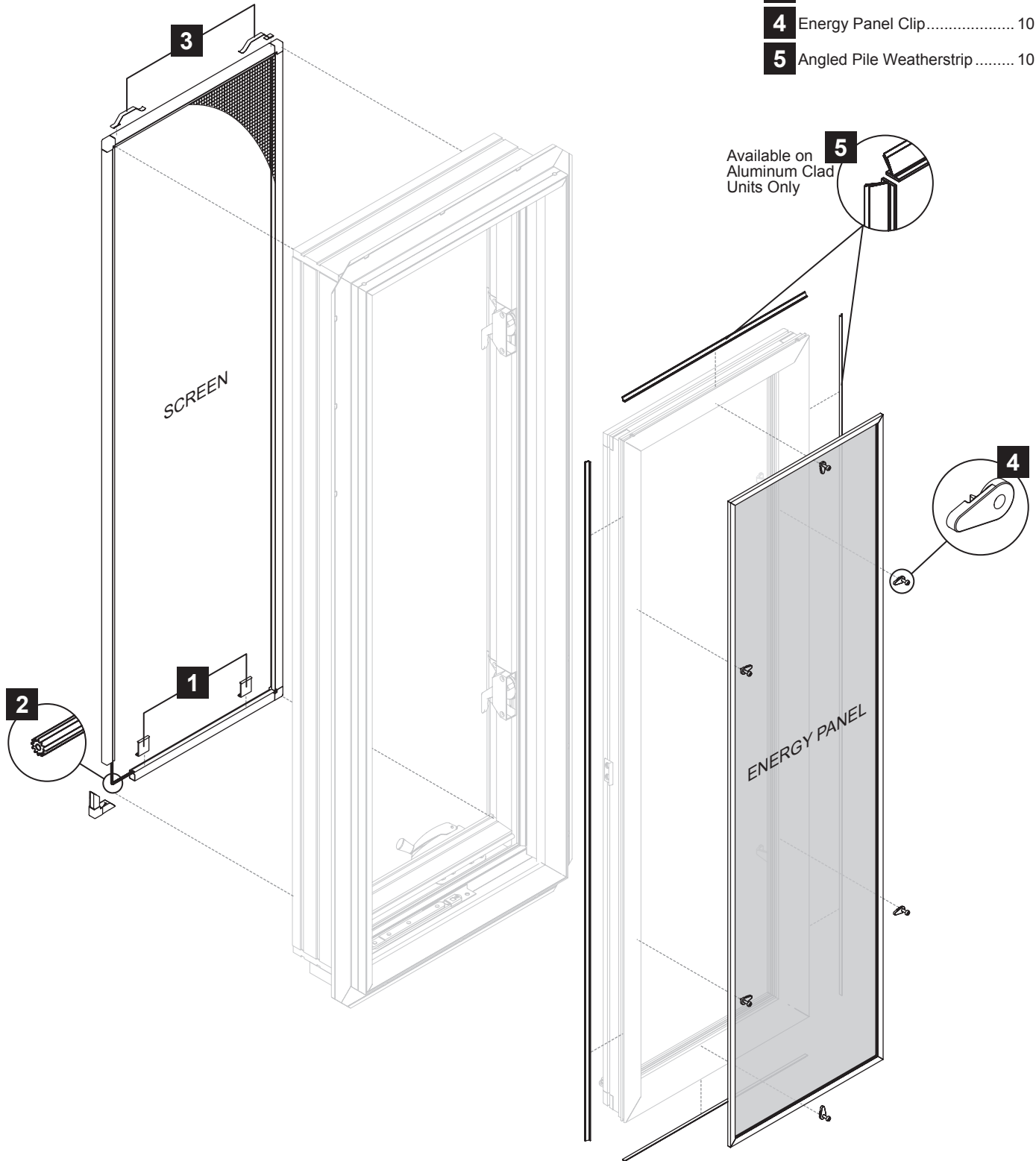



CASEMENT

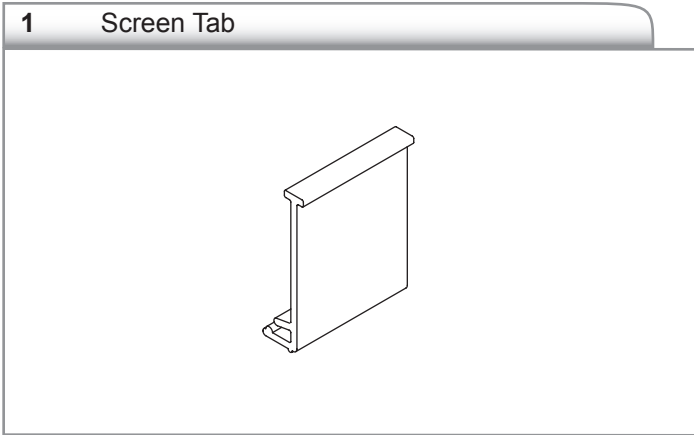

Part Number: 750763
Extrusion Number: 2023

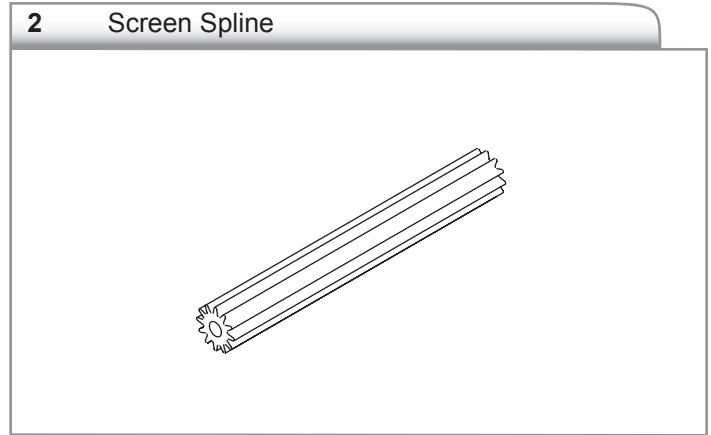

Configured Number: C761554
Extrusion Number: 1018

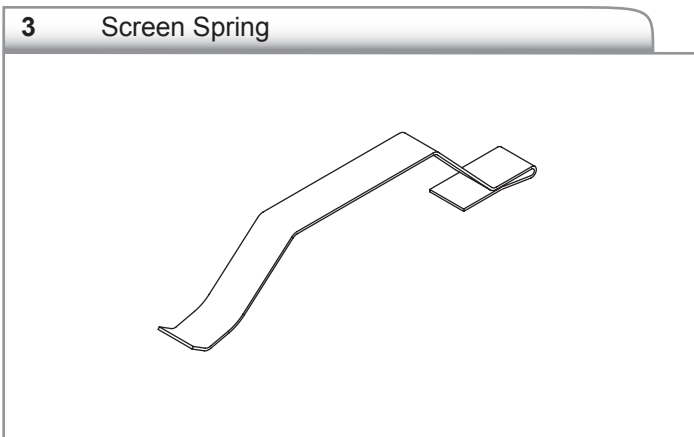

Part Number: 972570

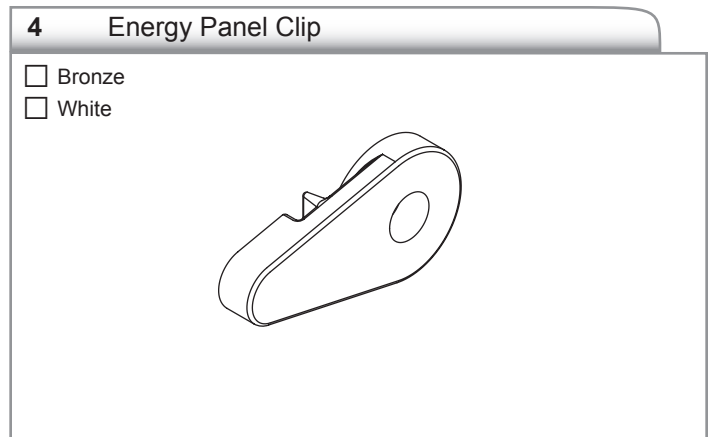

Part Number: (Bronze) 984095
(White) 984096

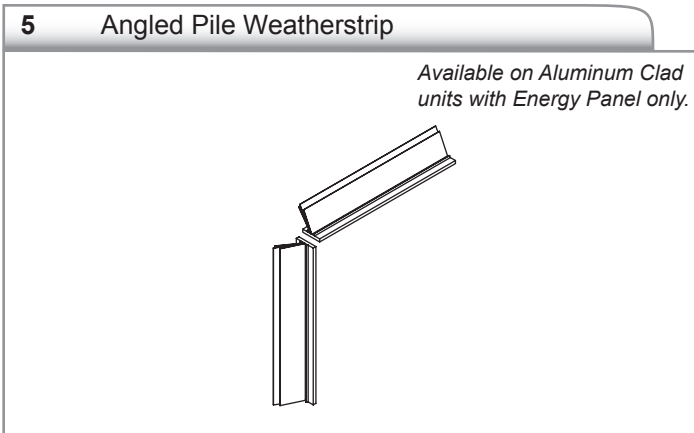

Configured Number: C983937